

Gastight Rectangular Shut-Off Damper, Type GD-R

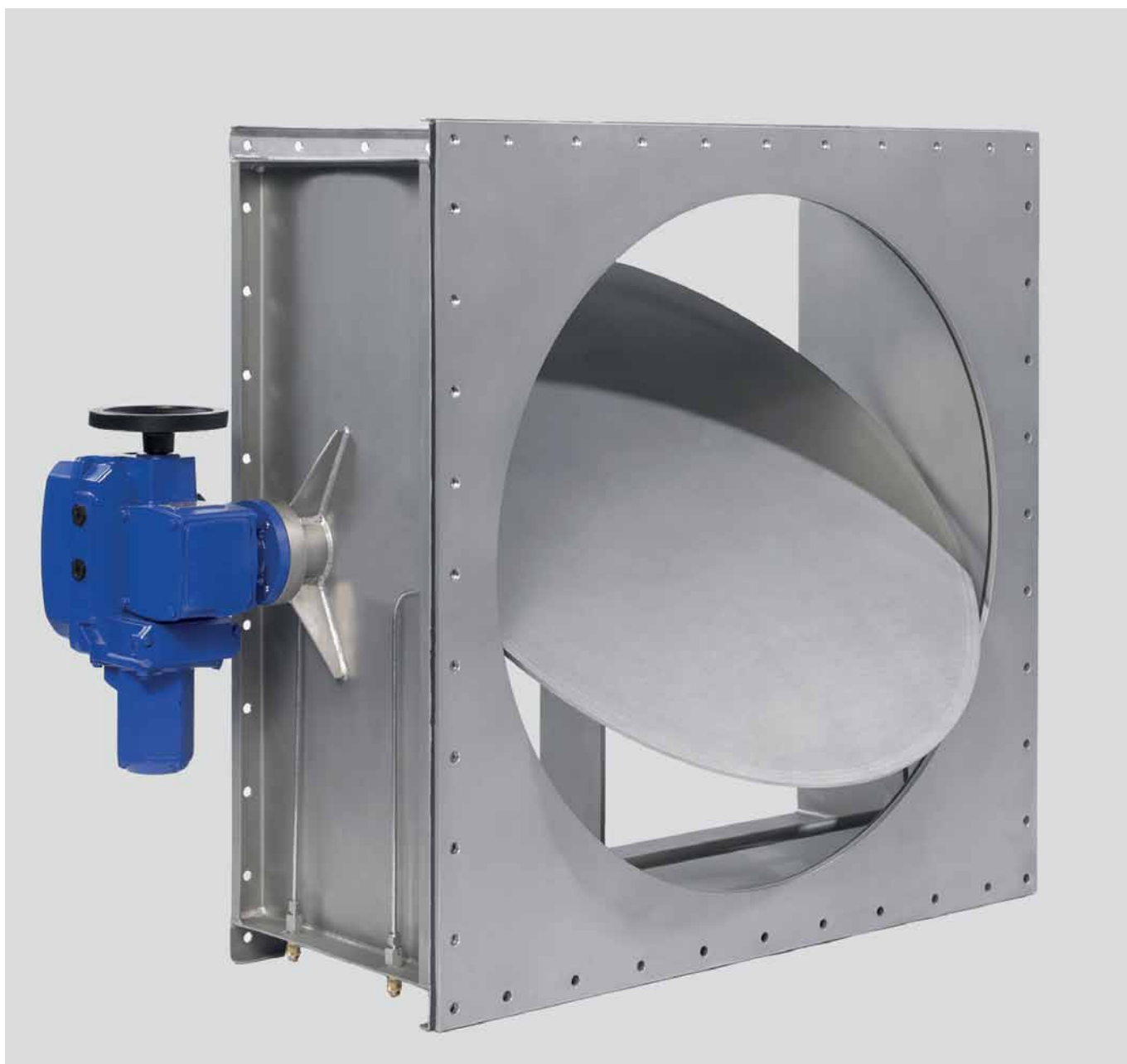

Gastight Shut-Off System

Gastight Rectangular Shut-Off Damper, Type GD-R

Components such as damper systems used in ventilation systems for sensitive areas, like the chemical, the pharmaceutical and the nuclear industry have to fulfil high leak tightness requirements.

The Gastight Rectangular Shut-Off Damper, type GD-R, surpasses by far the leak tightness requirements specified in DIN 25 496 (Ventilating components in nuclear facilities).

Krantz's Gastight Rectangular Shut-Off Damper, type GD-R, guarantees a maximum of safety and reliability thanks to

- its design,
- its system and
- the special damper mechanism.

Quality and safety characteristics

- The specially designed kinematical mechanism secures the damper blade at the end positions "open" and "close" by means of special toggle levers in case of a failure of energy support.
- Two concentric sealing rings fixed to the damper seat create high tightness as well as a test groove in the gap between the two sealing rings. In order to test the leak free seat of the damper blade the test groove can be connected to an appropriate seal test device via a fast acting coupling from outside the damper.
- To protect the sealing the damper blade starts the opening process with a linear movement. This movement is created by a special lever system, so first the damper runs parallel and after reaching a certain distance the movement turns automatically into a rotating motion. This mechanism avoids transverse loading force to the damper sealing.
- Double shaft transition sealing. Connections to test tightness of shaft transition during operation available on demand.
- Housing, damper blade and lever mechanism made of stainless steel.
- All media-touched parts are welded continuously and without gaps to ensure an easy decontamination.
- The housing, the damper seat and the shaft transition surpass by far the leak tightness requirements of DIN 25 496.
- **Electrical, pneumatic and manual** actuators available. The electrical actuator is also available as spring return (fail-safe) version.



Opening of damper

Shaft rotation 0°

- Damper blade closed. Special toggle lever system keeps damper blade in position "Closed" (without auxiliary energy).



Shaft rotation 60°

- The damper blade is first pulled back in a linear movement (**No transverse loading force to the damper sealing**).



Shaft rotation 120°

- Damper blade tilts.



Shaft rotation 180°

- Damper blade opened. Special toggle lever system keeps damper blade in position "Open" (without auxiliary energy).



Dimensions

Gastight Rectangular Shut-Off Damper, Type GD-R

Damper in position "Open"

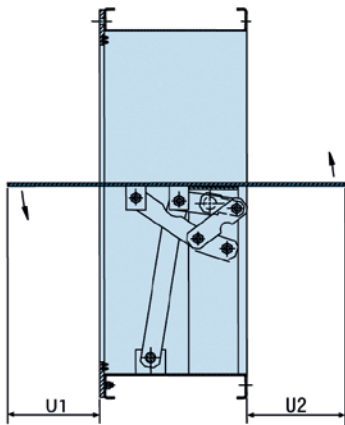

Damper in position "Closed"

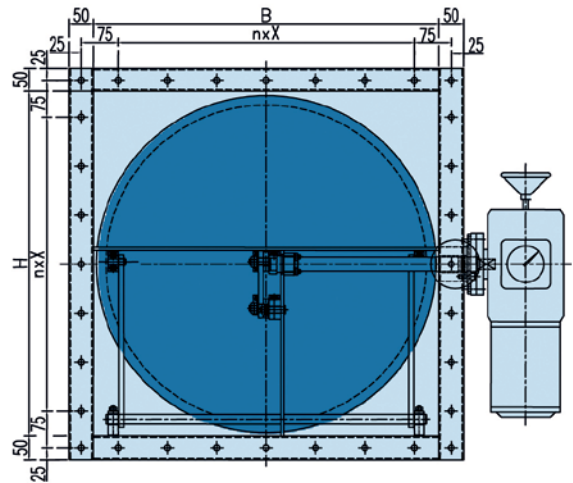
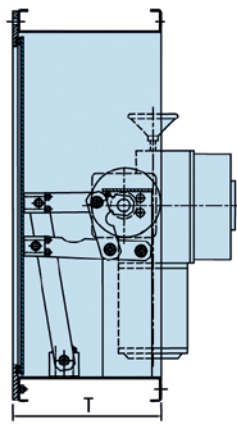

Nominal Sizes

The dimensions of the actuator depend on the chosen type and the requirements, e.g. spring return at energy loss. The damper is designed to be equipped with an

- electrical,
- pneumatic or
- manual actuator.

Type	B = H	T	n x X	U1	U2	Weight ¹⁾
GD-R...	mm	mm	mm	mm	mm	kg
400	400	300	3 x 100	37	51	65
500	500	300	4 x 100	87	101	80
600	600	300	5 x 100	137	151	95
700	700	300	6 x 100	187	201	110
800	800	400	7 x 100	180	195	150
900	900	400	8 x 100	230	245	180
1 000	1 000	400	9 x 100	280	295	210
1 100	1 100	400	10 x 100	330	345	240

¹⁾ The weights are given without actuator.

Text for tender

Gastight Rectangular Shut-Off Damper, Type GD-R

in solid and maintenance-free design, provided for systems with high tightness requirements. The damper housing and seat meet by far the permissible leakage rates specified by DIN 25 496.

General

- The damper is designed to operate without any failure at an operating pressure of 1.1 time the admissible operating pressure.
- The tightness of the damper blade's seat is testable in built-in situation.
- The position of the damper blade is visible from outside. The damper blade is secured by a special toggle lever system in the "Open" and "Close" position.
- All media-touched parts are welded continuously and without gaps to ensure an easy decontamination.

Design

- Robust damper housing made of stainless steel in gastight design according to the tightness requirements of DIN 25 496, table 3, with connection flanges on both sides.
- Seat plate made of stainless steel with a round opening and two circular sealing rings made from silicone rubber, designed as a test groove to test the required tightness of the damper seat. In order to test the leak free seat of the damper blade, the test groove can be connected to an appropriate seal test device via a fast acting coupling positioned outside the damper housing.
- Circular damper blade made of stainless steel, conveyed by a kinematical lever system. The specially designed lever system made of stainless steel secures the damper blade's end positions "Open" and "Close" by means of special toggle levers.
- To protect the elastic and aging resistant seal, the opening of the damper blade starts with a parallel travel before turning into a rotating movement later.
- Transmission of force to damper blade for the opening or closing process by means of external actuator, shaft and lever system. Gastight shaft transition through housing. Shaft sealing made from Perbunan.
- Actuator can be electrical, pneumatic, or manual. Electrical actuator also available with spring return (fail-safe).

Technical data

Fabricate:	Krantz
Type:	GD-R
Dimensions B x H x T:	see table "Nominal sizes" page 4
Actuator:	electrical / pneumatic / manual
Adm. operating temperature for damper:	- 40 °C to + 100 °C ¹⁾
Adm. operating temperature for actuator:	- 5 °C to + 70 °C ¹⁾
Adm. operating pressure:	10 000 Pa
Adm. pressure difference for damper blade in closing direction:	10 000 Pa
Adm. leakage rate for housing including shaft transition acc. to DIN 25 496:	10 l / (h · m ²) at 1 bar, 20 °C and $\Delta p = 2\,000\text{ Pa}$
Resistance to radiation:	$\leq 10^5\text{ Gy}$

¹⁾ Wider range of operating temperatures
available on request.



Contacts

Caverion Deutschland GmbH
Riesstraße 25
80992 München, Germany
Phone: +49 89 374288-500
Fax: +49 89 374288-520

Krantz Filter Systems and Dampers
Uersfeld 24
52072 Aachen, Germany
Phone: +49 241 434-1
Fax: +49 241 434-500

Production workshop
Mallersdorf
Schillerstraße 16
84066 Mallersdorf-Pfaffenberg, Germany

Claus Schweinheim
Division Manager
Krantz Filter Systems and Dampers
Phone: +49 241 434-501
Fax: +49 241 434-500
Mobile: +49 173 3888718
email: claus.schweinheim@krantz.de

Reinhold Goettgens
Sales Manager
Phone: +49 241 434-269
Fax: +49 241 434-500
Mobile: +49 174 1658185
email: reinhold.goettgens@krantz.de