

# Optional Sealing of Dampers in Fire & Smoke Rated Walls or Floor Openings

## Installation Instructions

### Only if required by the authority having jurisdiction

#### Application:

#### The need to seal the damper in the penetration is not required by Underwriters Laboratories.

PRICE dampers have been tested and approved to be mounted without the use of sealants around the perimeter space between the damper and the penetration. In certain cases, local codes request that this space be sealed to try and keep the integrity of the smoke barrier. These instructions have been produced to give direction where to apply caulk, if required by local codes. Suggested brands of caulk to use are Dow Corning 999, Dow Corning Silastic 732, Nuflex 302 and GE RTV 108 Sealant. Read and follow the sealant manufacturer's directions. Apply a continuous bead of caulk in the areas shown below. Do Not Apply sealant within the required expansion gap between the damper and the fire rated wall or floor. Allow the sealant to set up and become tack-free before operating the damper. See PRICE's standard installation instructions for the basic installation of the damper. These instructions are for use following damper installation. **Permission from the local codes inspector should be acquired before use of these instructions, to insure conformity with the local codes.**

- (1) Fire and smoke rated wall or floor
- (2) Retaining Angles
- (3) Fire, Smoke or Combination Fire/Smoke damper
- (4) Sleeve
- (5) Fasteners
- (6) Sealant to Wall
- (7) Sealant to Sleeve

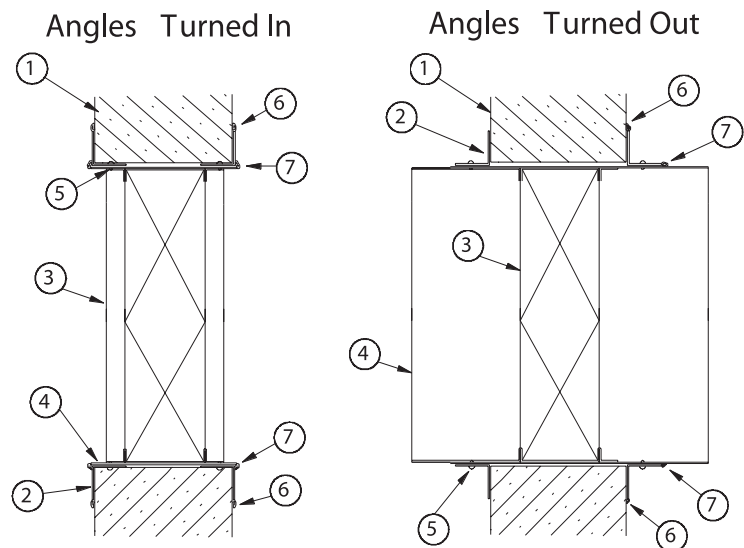

#### Procedure:

1. Follow PRICE's standard/general installation instructions for proper installation of the damper in the wall / floor.
2. Clean all areas where the sealant is going to be applied. Remove dirt, oil, grease, or moisture from surface to be sealed. Allow to dry thoroughly.
3. Using G.E. RTV 108, Dow Corning Silastic 732 RTV, Nuflex 302 or Dow Corning 999 Silicone Caulk, apply a continuous bead around the outside perimeter of the retaining angle, sealing them to the fire wall/floor (6). Do not apply caulk between angle and wall/floor. Also apply a continuous bead between the retaining angle and the damper sleeve(7). Be sure to seal the joints/corners of the retaining angles.
4. Be sure not to apply or get sealant within the required expansion gap between the sleeve and the fire wall/floor penetration. This gap is necessary for thermal expansion in the event of a fire.
5. After sealant is applied and before it sets-up, press the surface of the sealant in place to dispel any air. Do not operate the damper until the sealant has become tack-free.

**This instruction sheet has been reviewed and accepted by Underwriters Laboratories due to test performed by PRICE.**

#### Manufacturer's Recommendations

All moving parts of the damper must be inspected and cycled at intervals not greater than every six months and in accordance with the latest edition of NFPA 90A, 92A, local codes and the actuator manufacturer. In addition, fuse links shall be removed and inspected for corrosion. Dry lubricants are recommended.